

Design Aspects for 5G Architectures

The SESAME and COHERENT approach

Alexandros Kostopoulos¹, Ioannis Chochliouros¹, Fang-Chun Kuo², Roberto Riggio³, Leonardo Goratti³, Navid Nikaein⁴, Ioannis Giannoulakis⁵, Jordi Pérez-Romero⁶, Tao Chen⁷, Rebecca Steinert⁸, Dorin Panaitopol⁹

¹Hellenic Telecommunications Organization S.A., ²Traveling, ³FBK Create-Net, ⁴Institut Eurecom, ⁵National Centre for Scientific Research “Demokritos”, ⁶Universitat Politècnica de Catalunya, ⁷VTT Technical Research Centre of Finland, ⁸SICS Swedish ICT, ⁹Thales

Abstract—The exponential growth of mobile data traffic still remains an important challenge for the mobile network operators. In response, the 5G scene needs to couple fast connectivity and optimized spectrum usage with cloud networking and high processing power, optimally combined in a converged environment. In this paper, we investigate two 5G research projects; SESAME [1] and COHERENT [2]. We consider the proposed 5G architectures and the corresponding key network components, in order to highlight the common aspects towards the 5G architecture design.

Keywords—5G networks; architecture design; SESAME project; COHERENT project; software-defined networking.

I. INTRODUCTION

Mobile data traffic and services, fueled by new demanding personalized applications, proliferate at an immense rate, radically increasing the demand in infrastructure resources so as to keep user experience at a satisfactory level. Up to now, this ever-increasing demand has been fulfilled by the continuously evolving technological framework (mainly by 3G and 4G), which has offered improved coverage and capacity as well as improved resource usage. However, the long anticipated 5G model needs to involve a paradigm shift, i.e. establish a next generation network framework achieving reliable, omnipresent, ultra-low latency, broadband connectivity, capable of providing and managing critical and highly demanding applications and services. The fresh, groundbreaking advances in the field are expected to enforce revolutionary changes in network infrastructure and management, thus offering the power to “align with” a demanding set of diverse use cases and/or related scenarios. For all these purposes, the 5G scene needs to couple fast connectivity and optimized spectrum usage with software-defined networking (SDN) and high processing power, optimally combined in a converged environment.

In the *Digital Agenda for Europe*, the European Commission (EC) has set ambitious goals regarding the digital life of European citizens while, *at the same time*, significantly sharpening the edge of the capacity of European players to compete in ICT areas. With this background, the advent of the 5G networks era is now a centerpiece on the future digital life agenda. The European path towards 5G has been carefully planned by the European 5G Association and other appropriate

stakeholders. The common understanding and the common expectation is that *5G will not be a simple upgrade of the air interface, but that it will fuel the evolution of the whole mobile Internet ecosystem to “meet” the needs for a connected life.*

In order to address the aforementioned research challenges, several new projects have been retained by the EC in response to the *First Call of the 5G Infrastructure Public Private Partnership (5G-PPP)* [3]. The 5G-PPP has been initiated by the European Commission and industry manufacturers, telecommunications operators, service providers, SMEs and research institutes. One core intention for the 5G-PPP is to create a common research direction and path in order to “boost the deployment and adoption of the forthcoming 5G networks”.

In this paper, we investigate two actual research projects, i.e.: 5G-PPP SESAME [1] and COHERENT [2]. We consider the proposed 5G architectures and the corresponding “key-network” components, in order to “highlight” the common aspects towards the proper and innovative design of the 5G networks. The potential benefits from both approaches could trigger the interest of Communications Service Providers (CSPs) such as Mobile Network Operators (MNO), Mobile Virtual Network Operators (MVNO) and Over-The-Top (OTT) content and service providers, allowing them to “gain an extra share” in the network market, by pursuing emerging business models. Following this direction, novel business cases will produce added value from any kind of infrastructure or application that has the potential to be offered “*as a Service*”.

SESAME targets innovations around three central elements in 5G, that is: (i) The placement of network intelligence and applications in the network edge through Network Functions Virtualization (NFV) and Edge Cloud Computing; (ii) the substantial evolution of the Small Cell (SC) concept, already mainstream in 4G but expected to deliver its full potential in the challenging high dense 5G scenarios, *and*; (iii) the consolidation of multi-tenancy in communications infrastructures, allowing several operators/service providers to engage in new sharing models of both access capacity and edge computing capabilities. SESAME proposes the Cloud-Enabled Small Cell (CESC) concept, a new multi-operator enabled Small Cell that integrates a virtualized execution platform for deploying Virtual Network Functions (VNFs).

The COHERENT project aims to develop a unified control and coordination framework for 5G heterogeneous radio access

networks (RANs), with the emphasis on software defined networking for RAN programmability, in particular efficient radio resource modelling and management, and flexible spectrum management. COHERENT introduces the novel network abstraction concept to enable an efficient and scalable solution for network-wide coordination in heterogeneous mobile networks (HMNs). The network abstraction abstracts physical and MAC layer states, behaviors and functions of different mobile networks, feeding to the high layer centralized control entity a simple -but sufficient- annotated network graph for network-wide resource coordination. COHERENT focuses on the design and development of control architecture, protocols and algorithms to aggregate abstracted information from radio network entity and present as different type of annotated network graphs to upper control layers for high-level resource allocation and spectrum management.

The paper is organized as follows: Section II presents the scope of the essential SESAME components, the key-features of the system and the overall architecture. Correspondingly, Section III considers the aforementioned features for the COHERENT project. Section IV investigates the common design aspects of the both proposed 5G architectures. We conclude our remarks in Section V.

II. SESAME 5G ARCHITECTURE

A. Scope of SESAME components

SESAME proposes the CESC concept, which is a new multi-operator enabled Small Cell that integrates a virtualized execution platform (i.e., the Light Data Centre (DC)) for deploying VNFs, supporting powerful *Self-x* management and executing novel applications and services inside the access network infrastructure. The Light DC will feature low-power processors and hardware accelerators for time critical operations and will constitute a high manageable clustered edge computing infrastructure. This approach will allow new stakeholders to dynamically enter the value chain by acting as neutral host providers in high traffic areas where densification of multiple networks is not practical. The optimal management of a CESC deployment is a key challenge of SESAME, for which new orchestration, NFV management, virtualization of management views per tenant, “*Self-x*” features and radio access management techniques will be developed.

At this point, it is useful to provide definitions of terms and processes so that to describe the SESAME main concepts.

- *Small Cell (SC)*: It implicates the essential well-known definition which does not change in the context of SESAME.
- *Execution infrastructure, micro server (μS)*: Specific hardware that is placed probably inside the Small Cell and provides processing power (also potentially some memory and storage capabilities).
- *CESC*: The Small Cell device which includes a micro server in hardware form.
- *Cluster of CESC*s: A group of CESC

coordinated. As a trivial case, one CESC can be called CESC cluster.

- *Light Data Centre (Light DC)*: The hardware entity composed by the micro servers of the CESC
- *CESC Manager (CESCM)*: The architectural component in charge of managing and orchestrating the cloud environment of the Light DC, as well as management of small cell functions. It can manage, *at the same time*, multiple clusters, a cluster or a single CESC.
- *Virtual Infrastructure Manager (VIM)*: Manager of the hardware and networking resources (lifecycle, provision, placement, operation) constituting a cluster of micro-servers, namely the Light DC, and the networking nodes and links (virtual and physical).

In reference to the SESAME approach, the Small Cell concept is evolved so that not only be able to provide multi-operator radio access capacity with virtualized Small Cells that can be integrated within the operator (i.e.: the tenant) infrastructures, but also to be able to deliver a virtualized execution environment for providing Cloud services at the network’s edge. In order to achieve this, *however*, the Small Cell needs to provide mobile-edge computing (MEC) capabilities ([4], [5]) which, *in turn*, will allow the virtual or mobile operators to increase the capacity of their own 4G/5G RAN infrastructures or to extend the range of their provided services, while maintaining the required agility to be able to offer these extensions, on demand.

However, apart from being able to *abstract* these resources, some considerations need to be made on “*how to separate or combine the network and the computing resources*”, and also, *which small cell functions should be physical network functions and which ones should be virtual*.

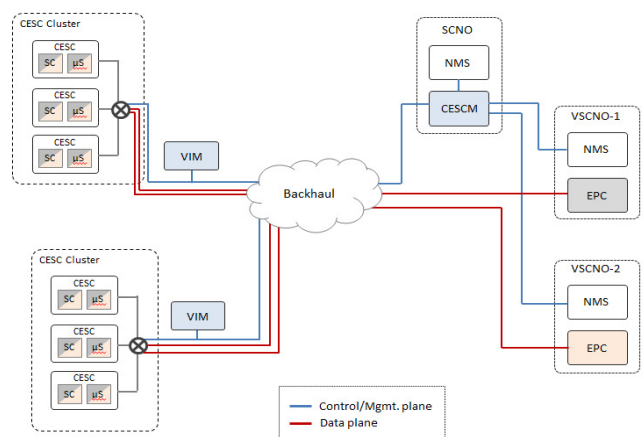

Fig. 1. Scope of SESAME essential components

The SESAME approach to the above challenge takes place by enhancing the Small Cells with micro servers that are able to provide virtualized computing and networking resources and by being able to form clusters, thus creating a Light DC at the

edge. This Light DC is further complemented by additional components that reside either close to the edge or to the backbone such as the VIM or the CESC, in order to provide the proper reference points -or scope- for the whole network, as depicted in Figure 1.

B. Key Features of the SESAME System and Architecture Principles

The key innovations proposed in the SESAME architecture focus on the novel concepts of virtualizing Small Cell networks by leveraging the paradigms of a multi-operator (multi-tenancy) enabling framework coupled with an edge-based, virtualized execution environment.

SESAME falls in the scope of these two principles and promotes the adoption of Small Cell multi-tenancy, i.e., multiple network operators will be able to use the SESAME platform, each one using his own network *slice*. Moreover, the idea is to endorse the deployment of Small Cells with some virtualized functions, with each Small Cell containing also a micro-server through appropriate front-haul technology. Together with the SC, they form the CESC and a number of CESC's form the *CESC cluster* capable to provide access to a geographical area with one or more operators.

At this point, we provide a brief description of the two main technological fields that constitute the main fields of innovation of SESAME. This kind of *decomposition* has been the starting point for building -at the next following stage- an accurate framework for the SESAME architecture, which is depicted in Fig. 2. To that end, the NFV technology is going to be used as an enabler that will offer a virtualization platform and meet the requirements of SESAME, namely NFV-driven small cell functions and NFV-based network services.

In general terms, SESAME scenarios assume a certain venue (e.g. a mall, a stadium, an enterprise, etc.) where a Small Cell Network Operator (SCNO) has deployed a number of CESC's that provide wireless access to end-users of different operators (tenants), denoted as Virtual Small Cell Network Operators (VSCNOs), according to specific Service Level Agreements (SLAs). 3GPP specifications have already added some support for Radio Access Network (RAN) sharing [6]. Although two main architectures are identified, namely Multi-Operator Core Network (MOCN) where the shared RAN is directly connected to each of the multiple operator's core networks, and Gateway Core Network (GWCN) where a shared core network is deployed so that the interconnection of the multiple operator's core networks is done at core network level, the MOCN case has been identified as the exclusive enabler for multi-tenancy features in SESAME platform.

The infrastructure deployed by the SCNO consists of a number of CESC's and the corresponding management systems (see, *for example*, the current 3GPP framework for network management in RAN sharing scenarios [7]-[9]). Assuming LTE technology as the contextual framework, the interconnection of the CESC's of the SCNO to the Evolved Packet Core (EPC) of each tenant (VSCNO) is done through the S1 interface, delivering both *data* (e.g., transfer of end-users traffic) and *control* (e.g., activation of radio bearers) plane functions.

The CESC offers computing, storage and radio resources. Through virtualization, the CESC cluster can be seen as a cloud of resources which can be sliced to enable multi-tenancy. Therefore, the CESC cluster becomes a neutral host for mobile SCNO -or VSCNO- who want to share IT and network resources at the edge of the mobile network. In addition, cloud-based computation resources are provided through a virtualized execution platform. This execution platform is used to support the required VNFs that implement the different features/capabilities of the Small Cells (and eventually of the core network) and the cognitive management and *Self-x* operations [10], as well as the computing support for the mobile edge applications of the end-users [11].

The CESC clustering enables the achievement of a micro scale virtualized execution infrastructure in the form of a distributed data center, i.e. the Light DC, enhancing the virtualization capabilities and process power at the network edge.

Network Services (NSs) are supported by VNFs hosted in the Light DC leveraging on SDN and NFV functionalities that allow achieving an adequate level of flexibility and scalability at the cloud infrastructure edge. More specifically, VNFs are executed as Virtual Machines (VMs) inside the Light DC, which is provided with a hypervisor (based on KVM) specifically extended to support carrier grade computing and networking performance.

Over the provided virtualized execution environment (Light DC), it is possible to chain different VNFs to meet a requested NS by a tenant (i.e., a mobile network operator). Note that, in the context of SESAME, a NS is understood as a collection of VNFs that jointly supports data transmission between User Equipment (UE) and operators' EPC, with the possibility to involve one or several service VNFs in the data path. Therefore, each NS is deployed as a chain of SC VNFs and Service VNFs.

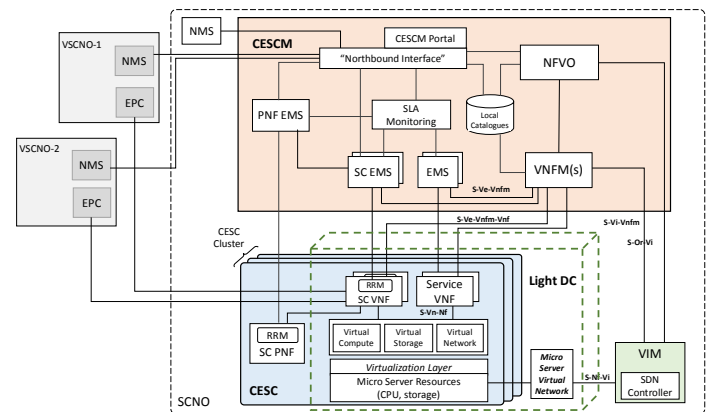

Fig. 2. SESAME overall architecture

Finally, the CESC is the central service management and orchestration component in the overall architectural depiction (as shown in Fig. 2). Generally speaking, it integrates all the necessary network management elements, traditionally suggested in the 3GPP framework, such as the Element Management System (EMS) and the novel recommended functional blocks of NFV MANAGEMENT and Orchestration

(MANO) [12], [13]. A single instance of CESC is able to operate over several CESC clusters, each constituting a Light DC, through the use of a dedicated VIM per cluster. The CESC is connected through the Northbound Interface with the Network Management Systems (NMS) of the SCNO and the VSCNOs, providing each VSCNO with a consolidated view of the portion of the network that they are able to manage. Finally, the CESC includes a portal that constitutes the main graphical frontend to access the SESAME platform for both SCNO and VSCNOs.

With regard to interfaces, it has to be noted that Figure 2 mostly depicts reference points -which may contain one or more actual interfaces- between architectural layers. Each reference point label starts with “S-” to differentiate it from interfaces defined in ETSI NFV ISG documents (and in specific Vi-Vnfm, Or-Vi, Ve-Vnfm, Nf-Vi) – although in many cases the functionality of the reference point will be almost aligned to the ETSI definitions.

III. COHERENT 5G ARCHITECTURE

A. Scope of COHERENT components

The COHERENT project aims to design, develop and showcase a novel control framework for 5G heterogeneous mobile networks (HMN), which leverages the proper abstraction of physical and MAC layer in the network and a novel programmable control framework, to offer operators a powerful means to dynamically and efficiently control spectrum and radio network resources in their increasing complex HMN. To this aim, COHERENT proposes the proper abstraction of physical and MAC layer states, behaviors and functions to enable a centralized network view of the underlying radio networks. The centralized network view with sufficient -but abstracted- information on spectrum, radio links, interference, network topology, load information, and physical layer reality is essential to enable optimal resource allocation in the network. The innovative impact of the COHERENT project is the development of an additional programmable control framework, on the top of current control planes of operators’ mobile networks, being aware of underlying network topology, radio environment, traffic conditions and energy consumption, and being able to efficiently coordinate wireless network resources cross the border of cells.

Below, we provide definitions of terms so that to describe the COHERENT main concepts:

- *Radio Transmission Point (R-TP)*: R-TP is a radio access point implementing full or partial RAN node functions, while rest of functions are offloaded to and handled by the vRP. An R-TP may include partial control plane functionalities.
- *Virtual Radio Processing (vRP)*: vRP is a computing platform allowing for centralized processing of full or partial RAN node functions (including the user plane and the control plane) offloaded from one R-TP or multiple R-TPs. A vRP may include control plane functions.

- *Radio Transceiver (RT)*: RT is a logical radio access entity with full RAN node functions, which is the flexible combination of R-TP, vRP and RTC functions. A set of RTs is forming a radio access network which is coordinated and controlled by C3. There are multiple physical and virtual resources and components in one RT. Some examples of physical RTs include LTE eNBs in cellular networks or WiFi APs in the WLANs. An RT could be composed by one vRP (virtual device) and one or more R-TPs (physical devices). For example, in the Cloud-RAN architecture the R-TP coincides with the RRH, while the vRP coincides with the BBU Pool, however several other functional splits are considered in this project. In some particular case, e.g., D2D, RT could be an UE, being a relay node.
- *Transport Node (TN)*: TN is the entity located between RTs and core network, with the role of transporting and delivering data plane packets. A set of TNs is forming a back-haul / front-haul network whose data plane can be configured by the C3. A network switch is an example of Transport Node.
- *Real-Time Controller (RTC)*: A logical entity in charge of local or region-wide control, targeting at real-time control operations, e.g., MAC scheduling. It has local network view. It could run directly on one RT or on a virtualized platform and receives monitoring information gathered from one RT or multiple RTs. It can delegate control functionality to the RTC agent on the RTs. RTC communicates with an RTC agent/RTC agents on one RT or multiple RTs.
- *Central Controller and Coordinator (C3)*: A logical centralized entity in charge of logical centralized network-wide control and coordination among entities in RAN based on centralized network view. C3 could be implemented with distributed physical control instances sharing network information with each other. Sharing network information among C3 instance creates the logically centralized network view and therefore achieves logical centralized control and coordination.
- *Slice*: A network slice is defined as a collection of specific network services and RAT configurations, which are aggregated together for some particular use cases or business applications. A network slice can span all regions of the network: software programs running on cloud nodes, specific configurations of the transport network, a dedicated radio access configuration, as well as settings of the 5G devices. Different network slices contain different network applications and configuration settings. Some application modules in network slices may be latency-critical. For such a slice, these modules are located in the RTC.

To address the scalability and latency issues, two control mechanisms are designed for achieving programmable 5G RAN, namely network-wide control and real-time control as shown in Fig. 3. The Central Controller and Coordinator (C3)

is a logically centralized entity¹, which provides network-wide control/coordination for the networks. Based on the centralized network view, the SDN principles are applied in the design of the C3. For overcoming scalability issue in a large and dense RAN deployment, or for performance/reliability reasons, the logically centralized C3 could be implemented with distributed physical control instances sharing network information with each other. Sharing network information among C3 instance creates the logically centralized network view and therefore achieves logical centralized control and coordination. The distribution of abstraction shields higher layer from state dissemination and collection, making the distributed control problem a logically centralized one.

To overcome the latency challenge, the real-time controller (RTC) shown in Figure 3 is designed to offer real-time control. RTC should be close to the physical radio elements so that RTC could adjust to rapidly varying wireless networks. Furthermore, for the sake of prompt control, RTCs in the RAN do not coordinate with each other and therefore, the network information is not shared between RTCs. Therefore, RTCs perform distributed control in the RAN.

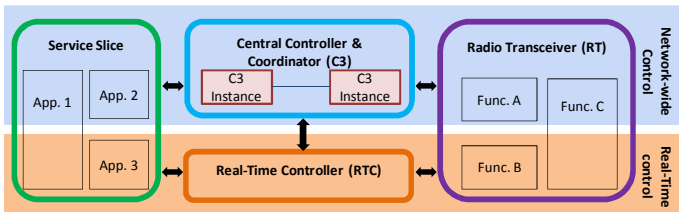

Fig. 3. COHERENT network wide control and real-time control

By separating control functionalities between the C3 and the RTC, the C3 makes decisions that affect the logically centralized network states, while the RTC handles control decisions for latency-sensitive network functionalities in radio transceivers (RTs) without coordinating with other RTCs. Moreover, different network slices contain different network applications and configuration settings. Some application modules in network slices may be latency-sensitive. For such a slice, these modules are located in the RTC. A more detailed analysis for COHERENT architecture is presented in [14].

B. Key Features of the COHERENT System and Architecture Principles

COHERENT architecture provides a programmable control and coordination that offers fine grain, real-time control without sacrificing scalability. Scalability and timeliness for control and coordination are achieved by introducing two control mechanisms, namely Central Controller and Coordinator (C3) as well as Real-Time Controller (RTC), as shown in Fig. 4. Furthermore, the programmability is driven by a key characteristic, namely abstraction. By receiving status reports from low layer entities, C3 maintains a centralized network view of the governed entities, e.g., transport nodes

¹ Note that defining C3 as a logically centralised entity neither prescribes nor precludes implementation details, e.g., the federation or hierarchical connection of multiple control instances.

(TNs) and Radio Transceivers (RTs) in the RAN. It is worth stressing that with the acronym RT we address a generic element in the RAN. For example, an RT could be a legacy LTE eNBs or a legacy WiFi AP or a New Radio² Base Station (NR BS). Similarly, an RT could be also a vRP with one or more R-TP. The specific applicability of the RT to any of those elements is purely an implementation choice.

Based on the Centralized Network View (CNV), the SDN principles are applied in the design of the C3. For overcoming the delay limitation between the C3 and the individual access network elements, latency-sensitive control functionalities are offloaded from the C3 to RTCs. The network entities (TNs and RTs) connect to C3 and RTCs through the southbound interface (SBI). The possible southbound communication protocols are OpenFlow [15], BGP-LS [16], PCEP [17], NETCONF [18], YANG [19], SNMP [20], LISP [21], OVSDB [22], CAPWAP [23] (for WiFi) and LWAPP [24] (for WiFi).

As mentioned before, C3 is a logically centralized control entity because the C3 instances share the network graphs with each other. The communication between controllers (RTC-C3, C3-C3) for sharing network graphs and offloading control functions is through east-west interface (EWi).

A network slice in the service plane is defined as a collection of specific network applications and RAT configurations. Different network slices contain different network applications and configuration settings as shown in Figure 4. Through northbound interface (NBi), the C3 and/or RTCs provide the required network view, namely slice-specific network view (SNV), for the network service slices so that network service slices could express desired network behaviors (by programming) without being responsible themselves for implementing that behavior (with hardware). The example of the NBi is Representational State Transfer (REST) [25].

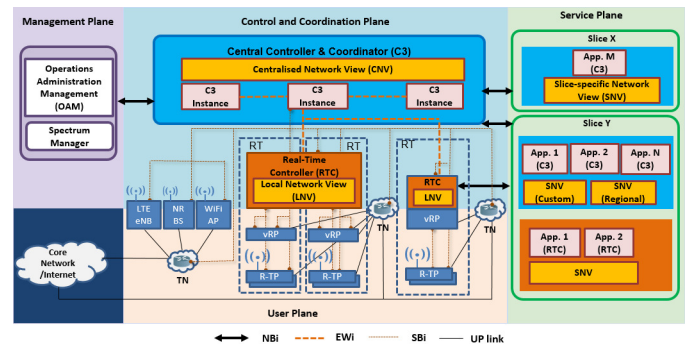

Fig. 4. COHERENT overall architecture

Some application modules in network slices may be latency-sensitive. For such a slice, these modules are located in the RTC. Additionally, monitoring modules which are latency-sensitive may need to operate close to the data source for reducing overhead and observe the network at high information granularity. The need for such monitoring modules may be service specific or operation specific. The examples of latency-sensitive network applications are flexible RAN function splitting in Cloud-RAN, MAC scheduling (regular, CoMP,

² New Radio (NR) is the 3GPP name for new 5G radio technology.

transmission mode selection, etc.), X2 HO decision, MAC/PHY (more generally cell) reconfiguration. In addition, most of the MEC application areas [4] are also relevant to RTC, e.g., localization, augmented reality, low latency IP service, etc. Moreover, the slice-specific network view (SNV) provided by the C3 could differ from the centralized one in the C3 in terms of space (e.g., it could be limited to a region) but also in terms of aggregation of nodes and edges. In general, we could have different views inside the same slice, according to what the application wants to do.

While the COHERENT control and coordination plane makes control decisions for RAN functions and sends the decisions to the network entities for executing the decisions, the management plane usually focuses on monitoring, configuring and maintaining the long-term decisions for network entities in the infrastructure, e.g., evaluation of the LSA rules between the operators, queries the databases managed by the National Regulation Agency (NRA) for the spectrum usage rules in the spectrum manager. The entities in management plane are connected to the C3 through NBI.

IV. COMMON 5G ARCHITECTURE DESIGN ASPECTS

SESAME mainly focuses on the Small Cells by proposing the Cloud-Enabled Small Cell (CESC) concept, which enables virtualizing and partitioning Small Cell capacity, as well as support of enhanced multi-tenant edge cloud services by enriching Small Cells with micro-servers. On the other hand, COHERENT focuses on the abstraction and control approaches in 5G radio access networks in order to orchestrate heterogeneous mobile networks (HMN) to a ubiquitous and unified service platform. Although each project intends to address different challenges, we may identify a range of design aspects, which are common for both projects:

Separation of control and data plane: In SESAME, the SDN approach of decoupling control and data plane functions is indeed particularly suitable to make global decisions across several, possibly collocated, Small Cells. In COHERENT, the separation of control and data plane allows the applications to programmatically control the heterogeneous mobile networks with lower complexity.

Controller for resource allocation: In SESAME, CESC Manager is the architectural component in charge of managing and orchestrating the cloud environment of the Light DC, as well as management of small cell functions. It can manage, at the same time, multiple clusters, a cluster or a single CESC.

The controller within the context of COHERENT is responsible for the cooperation and joint resource allocation in heterogeneous RAN. The control and coordination plane is comprised by C3 and RTC. C3 is a logical centralized entity, which orchestrates the behaviors of network entities (RTs and TNs) in the RAN so that network behaviors in the RAN are harmonized. RTC deals with the fast status update and control decision for R-TP and vRP with the response time in the order of milliseconds.

Virtualization and network slicing: A fundamental component of SESAME is the virtualization of Small Cell and their utilization and partitioning into logically isolated slices,

offered to multiple operators/tenants. Hence, multiple network operators are enabled to use the SESAME platform, each one using his own network slice. The main aspect of this innovation is the capability to accommodate multiple operators under the same infrastructure, satisfying the profile and requirements of each operator separately.

The network slices envisioned in COHERENT, span the whole protocol stack from the underlying (virtualized) hardware resources up to network services and applications running on top of them. A COHERENT network slice, is a composition of adequately configured network functions, network applications, and the underlying cloud infrastructure (physical, virtual or even emulated resources, RAN resources etc.), that are bundled together to meet the requirements of a specific use case or business model³.

Network and resource abstraction: In SESAME, abstraction has to deal with the available network resources. For example, VIM manages of the HW and networking resources constituting of a cluster of micro-servers, namely the Light DC, and the networking nodes and links (virtual and physical). Additionally, the abstraction layer of the virtualized resources of the CESC cluster is created and controlled by the VIM.

Apart from the abstraction of the available resources, COHERENT provides an additional level of abstraction with respect to the network state. COHERENT abstractions encompass representations and models of time-frequency resources, spatial capabilities (i.e. number of transmit and receive antennas), as well as throughput per network slice or per allocated resources. In principle any data structure can be used for storing and accessing abstracted representation of the network state (e.g., CQI defined in LTE). However, for unified large-scale coordination of infrastructure resources, structuring network information into network graphs in a systematic way offers effective representation of physical and virtual infrastructures.

V. DISCUSSION

From the above analysis, we realize that it is essential to introduce an architecture allowing for a cost- and time-efficient introduction of 5G that integrates a variety of revolutionary technologies combined with legacy existing mobile radio generations. Those technologies and layers will need to be managed as “one”. Furthermore, apart from supporting a fast growing overall mobile data volume and a significantly increased number of connected mobile devices, the 5G mobile infrastructure is intended to flexibly adapt to dynamically

³ It should be also referred the definitions of network slicing to highlight the consistencies of both projects with 3GPP [26]-[27]. In [28], a network slice is a network created by the operator customized to provide an optimized solution for a specific market scenario which demands specific requirements with end to end scope. According to 3GPP SA5 [8], a network slice instance is a set of Network Functions and the resources for these Network Functions which are arranged and configured, forming a complete logical network to meet certain network characteristics. Moreover, SA5 has provided the lifecycle of a network slice by describing the following phases; *preparation phase*, *instantiation*, *configuration and activation phase* (similar to the functionality of C3 in COHERENT), *run-time phase* (similar to RTC functionality in COHERENT), and *decommissioning phase*.

fluctuating traffic demands and a broad range of potentially new requirements of future service portfolios. The architecture design aspects presented above – including data/control plane separation, virtualization, network slicing and abstraction – are employed in order to address the aforementioned research challenges.

Last but not least, the 5G networks are expected to evolve the current business models, as well as bring new players within the market. For example, in SESAME, new market players, such as the third party infrastructure providers are envisaged to enter the market and thanks to the much finer spatial granularity of small cells, users could potentially be able to exploit broadband access to services and applications. In COHERENT, resource abstraction could further enhance the presence of the Mobile Virtual Network Operators (MVNO). We foresee that such evolution of the mobile market will be accelerated not only due to technological advances, but also due to business and economic changes.

ACKNOWLEDGMENT

This work was conducted within the framework of the 5G-PPP SESAME (Grant Agreement No. 671596) and 5G-PPP COHERENT project (Grant Agreement No. 671639), which is also funded by the Commission of the European Union.

REFERENCES

- [1] Small cells coordination for Multi-tenancy and Edge services (SESAME), EU H2020 5G-PPP project, website <http://www.sesame-h2020-5g-ppp.eu/>.
- [2] Coordinated control and spectrum management for 5G heterogeneous radio access networks (COHERENT), EU H2020 5G-PPP project, website <http://www.ict-coherent.eu/>.
- [3] 5G Infrastructure Public Private Partnership (5G-PPP), website <https://5g-ppp.eu/>.
- [4] Patel *et al.*, “Mobile-Edge Computing – Introductory Technical White Paper”, ETSI, 2014.
- [5] ETSI GS MEC-IEG 004 V1.1.1, “Mobile-Edge Computing (MEC); Service Scenarios”, 2015.
- [6] 3GPP TS 23.251 v13.1.0: “Network Sharing; Architecture and functional description (Release 13)”, March 2015.
- [7] 3GPP TS 32.101: “Telecommunication management; Principles and high level requirements (Release 12)”, September 2014.
- [8] 3GPP TS 32.130 v13.0.0: “Telecommunication management; Network sharing; Concepts and requirements (Release 13)”, January 2016.
- [9] 3GPP TS 36.300 v13.2.0: “Evolved Universal Terrestrial Radio Access (E-UTRA) and Evolved Universal Terrestrial Radio Access Network (EUTRAN); Overall description; Stage 2 Release 13”, December 2015.
- [10] B. Blanco, *et al.* “Design of Cognitive Cycles in 5G Networks”. In L. Iliadis and I. Maglogiannis (Eds.), *Proceedings of AIAI 2016, IFIP AICT 475*, pp.697-708, 2016. Springer International Publishing Switzerland.
- [11] J.O. Fajardo, F. Liberal, *et al.* “Introducing Mobile Edge Computing Capabilities through Distributed 5G Cloud Enabled Small Cells”, *Mobile Networks and Applications*, 21(4), pp.564-574, 2016.
- [12] NFV Management and Orchestration - An Overview, GS NFV-MAN 001 V1.1.1, European Telecommunications Standards Institute (ETSI), 2014.
- [13] I. Chochliouros, I. Giannoulakis, *et al.* “A Model for an Innovative 5G-Oriented Architecture, Based on Small Cells Coordination for Multi-tenancy and Edge Services”. In Iliadis and I. Maglogiannis (Eds.), *Proceedings of AIAI 2016, IFIP AICT 475*, pp.666-675, 2016 Springer International Publishing Switzerland.
- [14] COHERENT: Coordinated Control and Spectrum Management for 5G Heterogeneous Radio Access Network, Deliverable 2.2 “System Architecture and Abstractions for Mobile Networks”, June 2016.
- [15] “OpenFlow”, [Online]. Available: <https://www.opennetworking.org/sdn-resources/openflow>.
- [16] IETF RFC 7752, “North-Bound Distribution of Link-State and Traffic Engineering (TE) Information Using BGP”, 2016.
- [17] IETF RFC 5440, “Path Computation Element (PCE) Communication Protocol (PCEP)”, 2009.
- [18] IETF RFC 6241, “Network Configuration Protocol (NETCONF)”, 2011.
- [19] IETF RFC 6020, “YANG - A Data Modeling Language for the Network Configuration Protocol (NETCONF)”, 2010.
- [20] IETF RFC 1157, “A Simple Network Management Protocol (SNMP)”, 1990.
- [21] IETF RFC 6830, “The Locator/ID Separation Protocol (LISP)”, 2013.
- [22] IETF RFC 7047, “The Open vSwitch Database Management Protocol”, 2013.
- [23] IETF RFC 5415, “Control And Provisioning of Wireless Access Points (CAPWAP) Protocol Specification”, 2009.
- [24] IETF RFC 5412, “Lightweight Access Point Protocol”, 2010.
- [25] R. T. Fielding, “Architectural Styles and the Design of Network-based Software Architectures: Chap 5 Representational State Transfer (REST)”, 2010.
- [26] 3GPP SA WG2, 5G System Architecture – Phase 1. Available at http://www.3gpp.org/ftp/tsg_ran/TSG_RAN/TSGR_74/joint_RAN_SA_Wed_eve/RP-162540.zip.
- [27] 3GPP TR 38.913, “Study on Scenarios and Requirements for Next Generation Access Technologies (Release 14)”, October 2016. Available at: <http://www.3gpp.org/DynaReport/38913.htm>.
- [28] 3GPP TR 23.799, Study on Architecture for Next Generation System, December 2016.